

Nazava Murni

nazava®



WATER ♥ THAT CARES



WhatsApp



Instruction videos
use & maintenance



Activated warranty
here



How to throw &
recycle



Laboratory
Test Result

Made by Nazava - PT Holland For Water

More information and test results:

info@nazava.com

(+62) 22 6649061

www.nazava.com

Made in Indonesia

 @Nazava

 @NazavaWater

 @NazavaWater

 Nazava Water Filters

 Customer Service
0813 60862522



Murni



INSTRUCTION MANUAL



Easy



Affordable



Healthy



100%
Safe

1. SPECIFICATIONS

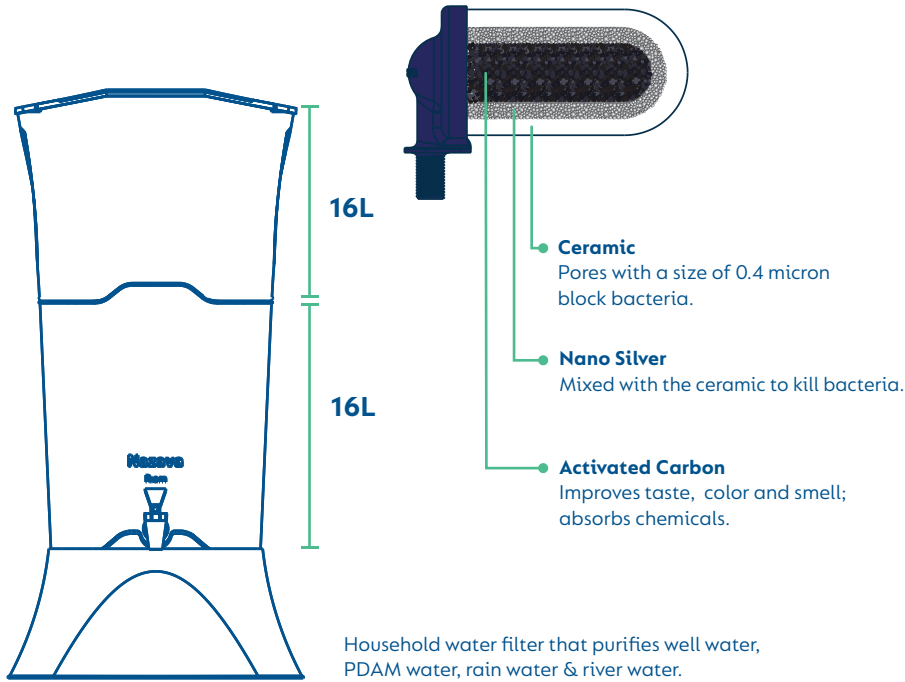

No Electricity



Tested in
30 laboratories



Filtration Speed
2-3 L/hour



No Boiling



Capacity
7000 L



Only valid for
manufacturing faults



Plastik Food-grade



Lifetime
**Up to
3 years***



Read & understand
this hint before
use water filter

This product has been tested as part of the
WHO International Evaluation Scheme
for Household Water Treatment Technologies.

*Depending on the water quality

2. COMPONENTS

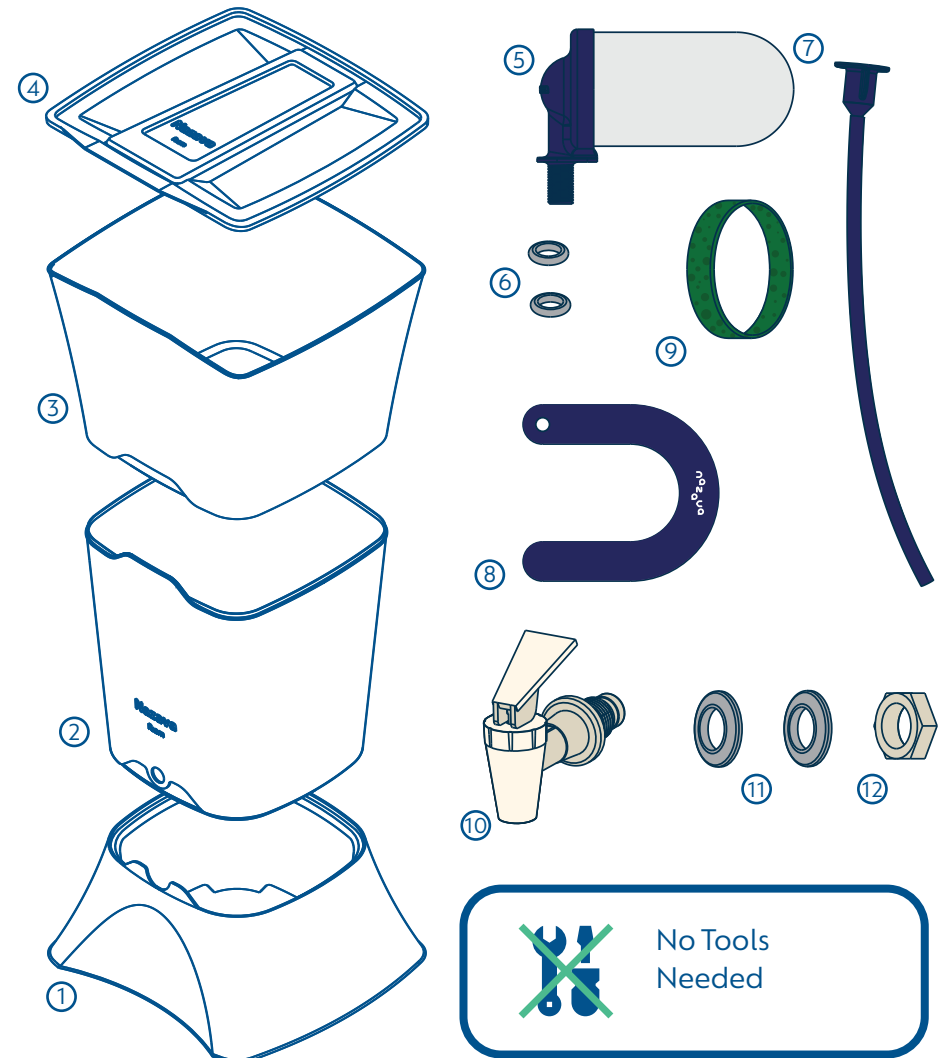

- ① 1x Base
- ② 1x Lower Container
- ③ 1x Upper Container
- ④ 1x Lid

- ⑤ 1x Nazava PROT3CT
- ⑥ 2x Seals for Nazava PROT3CT
- ⑦ 1x Hose
- ⑧ 1x Indicator
- ⑨ 1x Sponge

- ⑩ 1x Tap
- ⑪ 2x Seals for Tap
- ⑫ 1x Nut



No Tools
Needed

3. INSTALLATION 1/2



1. Wash your hands with soap. Clean all plastic elements of the Nazava Murni.

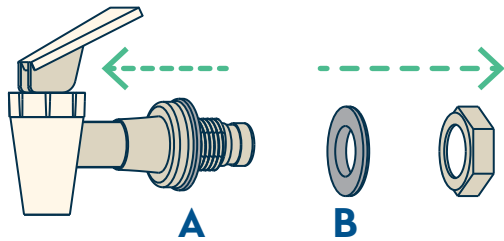

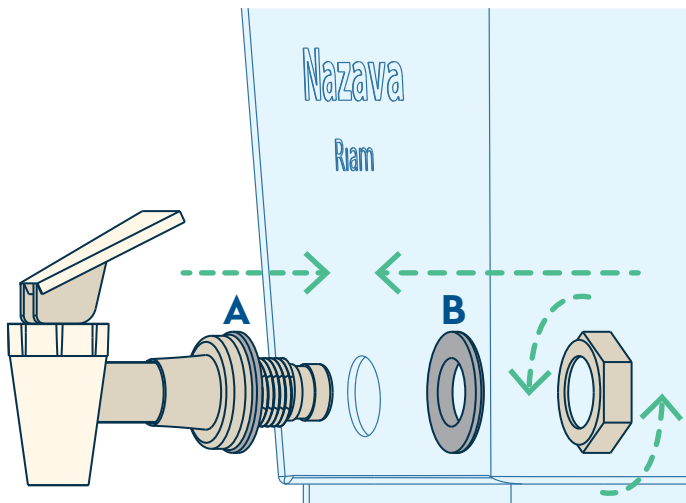

2. Remove the nut and seal B attached to the tap. Leave seal A on the tap.

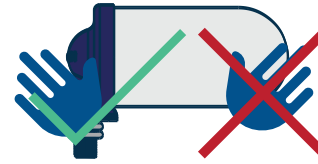

3. Install the tap and seal A from the outside of the lower container into the hole. Install seal B and tighten the nut from inside the container by turning the nut clockwise. Tighten firmly.

3. INSTALLATION 2/2



 Do not touch the ceramic part. Only touch the plastic part.

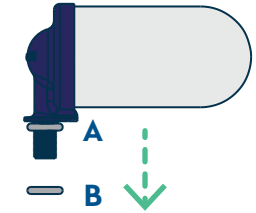

1. Remove seal B attached to Nazava PROT3CT. Leave seal A on the Nazava PROT3CT.

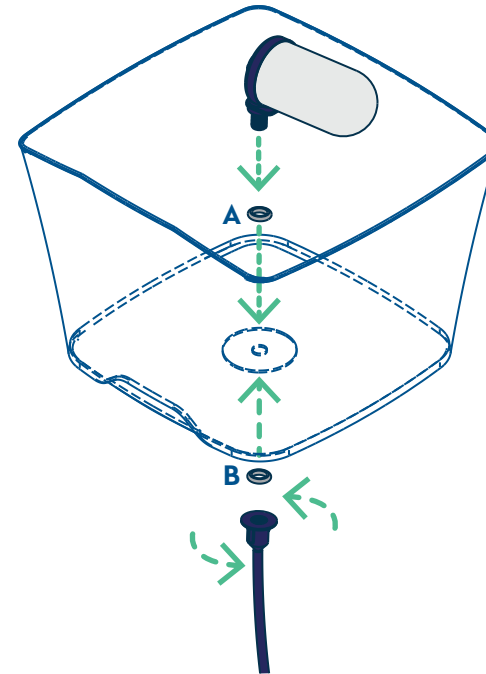

2. Install the Nazava PROT3CT and seal A into the hole inside the upper container. Install seal B and tighten the hose at the bottom of the container by turning the nut clockwise. Tighten firmly.

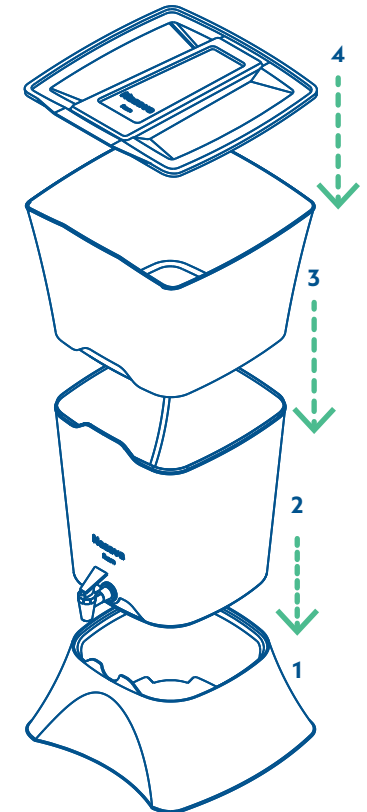

3. Place the lower container on the base, place the upper container on top of the low container. Cover the container with the lid.

4. FIRST USE



① ②

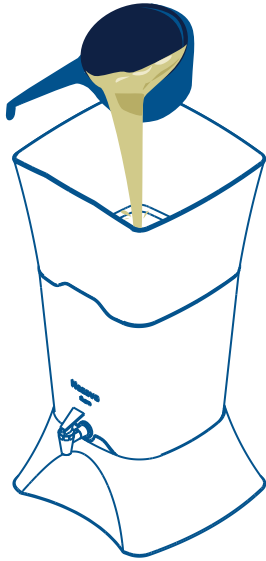

③

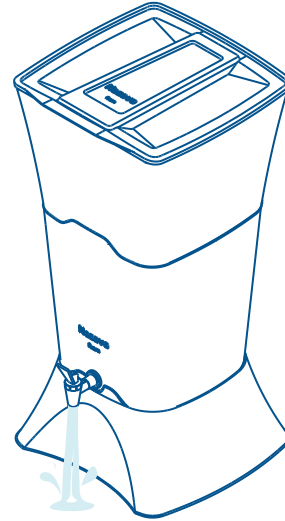

1. Make sure all parts are correctly installed.
2. Pour RIVER WATER, RAIN WATER, TAP WATER or WELL WATER into the upper container until full.
3. Throw away the first 15 litres of filtered water or when the lower container is full.

5. APPLICATION

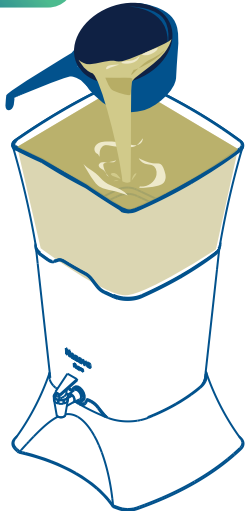

Refill the upper container. Wait for the water to Nazava PROT3CT into the lower container. After that, the water is safe to drink.

6. MAINTENANCE

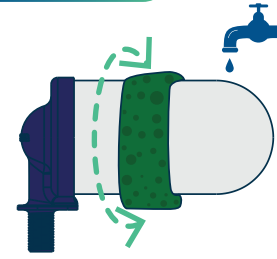

Do not use detergent or soap.

- A. When Nazava PROT3CT is clogged, scrub it with a sponge under running water.
- B. Wash containers if needed..
- C. Nazava PROT3CT can change color. Don't rub until it is white.

7. REPLACEMENT

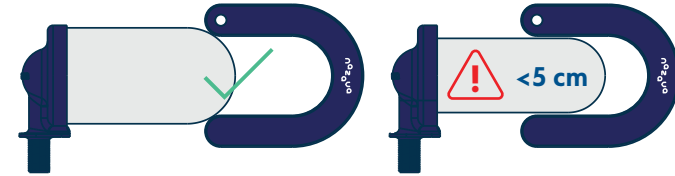

Nazava PROT3CT should be replaced when the diameter is less than 5 cm, or after 3 years of use.

8. TIPS

A. To speed the filtration process

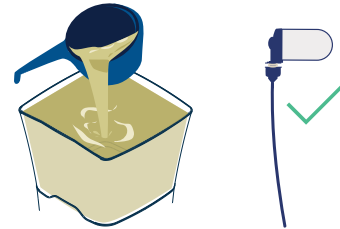

1. Fill the upper container to the rim with water.
2. Install the hose, it helps to increase filtration speed with 50%

B. Fill Nazava Murni in the afternoon, the next morning you will have enough water for your family

SAFETY INSTRUCTIONS

1. Do not carry the top container with water in it.
2. Do not purify water containing fluoride.
3. Do not place your Nazava Murni in direct sunlight.
4. Do not use boiling water.